

Task 1: determination of length and measures.

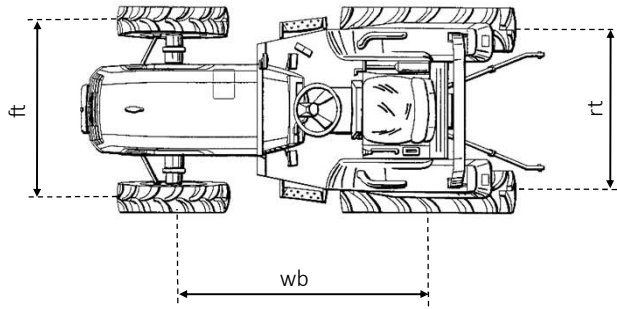

Parameter	Symbol	Value
Wheelbase	wb	m
Rear track	rt*	m
Front track	ft*	m
Rear tyre width	wr	m
Front tyre width	wf	m
Equivalent rear track	rt	m
Equivalent front track	ft	m

Task 2: experimental determination of the CoG position.

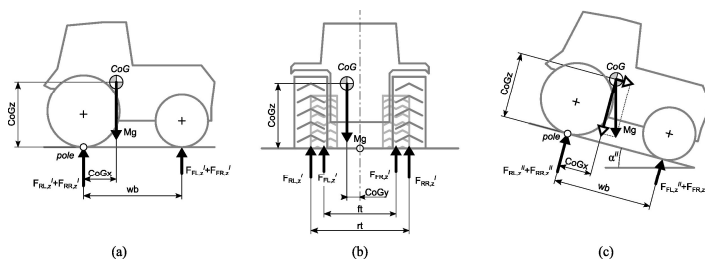

$$Mg = F_{RL,z}^I + F_{RR,z}^I + F_{FL,z}^I + F_{FR,z}^I$$

$$CoGx = \frac{F_{FL,z}^I + F_{FR,z}^I}{Mg} wb$$

$$CoGy = \frac{(F_{RL,z}^I - F_{RR,z}^I)rt^* + (F_{FL,z}^I - F_{FR,z}^I)ft^*}{2Mg}$$

$$CoGz = \frac{(F_{FL,z}^{II} + F_{FR,z}^{II})wb - Mg \cos\alpha^{II} CoGx}{Mg \sin\alpha^{II}}$$

Test	α [°]	$F_{RL} = F_A$ [N]	$F_{FL} = F_B$ [N]	$F_{FR} = F_C$ [N]	$F_{RR} = F_D$ [N]
Horizontal					
Longitudinal tilt					

M	CoG _x	CoG _y	CoG _z
kg	m	m	m

Task 3: calculation of lateral rollover instability angle.

$$\alpha^I = \arctan\left(\frac{\frac{rt}{2}\left(1 - \frac{CoG_x}{wb}\right) - CoG_y}{CoG_z}\right)$$

$$\alpha^{II} = \arctan\left(\frac{\frac{rt}{2} + \frac{CoG_x \cdot (ft - rt)}{2 \cdot wb} - CoG_y}{CoG_z}\right)$$

Instability type	α [°]
Phase I	
Phase II	

Task 3: experimental determination of lateral rollover instability angle.

Instability type	α [°]
Phase I	
Phase II	

